

Manual

K 100 PR

K 100 W PR

Measuring and control instruments
for pH and ORP measurements





DR. A. KUNTZE

GUTES WASSER MIT SYSTEM

Dr. A. Kuntze GmbH

Robert-Bosch-Str. 7a

D-40668 Meerbusch

Tel. +49-21 50-70 66-0

Fax +49-21 50-70 66-60

info@kuntze.com

www.kuntze.com

Contents

1. Your K 100	4
1.1 General and Safety instructions	5
1.2 Application	6
1.3 Intended use	6
1.4 Features	7
1.5 Technical data	8
2. Instructions for installation and connections	9
2.1 Dimensions	10
2.2 Installation K 100	11
2.3 Installation K 100 W	12
2.4 Connection diagram K 100	13
2.5 Connection diagram K 100 W	14
3. Operation of the instrument	15
3.1 How to adjust parameters	16
3.2 Where to look for information	17
3.3 Menu overview	18
4. Code and language	19
5. Adjustments for measurement	20
5.1 Calibration	21
5.2 Temperature compensation	22
5.3 ORP measurements	23
6. Adjustment of the controller	24
6.1 ON/OFF controller	25
6.2 P / PI controller as impulse-frequency controller	26
6.3 P / PI controller as pulse-pause controller	27
6.4 Activation and deactivation of the controller	28
6.5 Turn-on delay	28
6.6 External controller stop (digital input)	28
6.7 Manual operation of the relays	29
6.8 Limit values and Alarm	30
6.9 Dosage check	31
7. Data output	32
7.1 Current output	32
7.2 Current output as controller output	32
7.3 Serial interface RS485 (option)	32
8. Operation and maintenance	33
9. Service	35
9.1 Product info	35
9.2 Analog inputs	35
9.3 Erase settings (reset)	35
10. Error messages	36
Index	37
Customer settings - for reference!	39

1. Your K 100

Is an instrument by Dr. A. Kuntze GmbH which offers high quality and reliability for years.

It is one of our economy series K 100 with which we are trying to meet the rising demand for low cost / high end instrumentation.

The K 100 instruments are defined by an excellent value for money. They were developed to maximize functionality on standard applications.

Operation requirements are reduced to an absolute minimum: For standard electrodes no adjustments are required. The calibration solutions are automatically recognised, regardless of the order in which they are used. After every single calibration step the calibration curve is recalculated, so you can work with a 1-point calibration, if you like.

For any non-standard application you can alter all parameters connected with calibration: for restricted or outlying measuring ranges you can adjust the calibration solutions as well as the zero-point of your measurement which is defined by the inner buffer of the electrode.

All K 100 instruments have an integrated controller which provides bidirectional PI control, via two relays or as a steady-state controller via the analog output. You can define a turn-on delay to prevent incorrect dosage after power failure and operate the controller by remote control. Connect a level sensor, and the fail-safe will shut down the controller automatically in a low water situation. Activate the dosage check function to get an alarm if dosage achieves no results, indicating damages in the feeding lines.

Let's not forget the alarm function with minimum and maximum limit and turn-on delay...

You have certainly made a good choice. On the following pages you learn more about your K 100. If, however, you have further questions or are looking for information not included in this manual or if you are interested in supplementing products like sensors or flow cells or in our other instrument series, just give us a call - we will be delighted to help you!

1.1 General and Safety instructions

This manual applies to the following instruments:

Instrument and type	Revision date
K 100 PR	01/08
K 100 W PR	01/08

It contains technical information for the installation, start-up and maintenance. If you have any questions not included in this manual please contact your supplier or the official representative of Dr. A. Kuntze GmbH in your country.

We would like to point out that the warranties specified in our general trading conditions are valid only if

- installation, connections, adjustments, start-up, and maintenance of the instrument are carried out by authorized personnel with adequate qualification.
- the instrument is used according to the description in this manual.

Please check for damages immediately after receiving the instruments and report any damages within 24 hours to the delivering company. Never work with a damaged instrument.

Keep this manual at a safe place where you can always look up the safety instructions and the informations on handling and usage. According to DIN 61010 the manual is part of the product and must be maintained as long as the instrument is used, and given to the next owner if the instrument is sold.

This instrument was designed and built according to the safety measurements for electronic devices and has left our company in perfect working condition. To preserve this condition and to ensure safe usage follow all instructions carefully and pay special attention to all warnings issued in this manual. If the instrument is visibly damaged or has been stored inappropriately or if there are any doubts concerning safe usage, shut it down and make sure it cannot be restarted by accident.

You will notice that important safety instructions are highlighted:

WARNING highlights instructions for the protection of people. Disregarding these instructions may cause accidents and injuries!

ATTENTION highlights instructions for the protection of the instrument and the equipment. Disregarding these instructions may lead to damage or destruction of the instrument or equipment!

NOTE is used to highlight interesting details.

1.2 Application

The instruments K 100 PR and K 100 W PR can be used to measure and control the pH or ORP value of water. Both have an integrated controller with two set points. With this you can control actuators such as dosing pumps or valves to add chemicals until the desired pH or ORP value is reached and maintained.

Applications are detoxication of industrial waste water, water treatment, and disinfection.

While the controller is set to Automatic, it controls independently the dosing of possibly hazardous chemicals, according to the measured values.

For safety measures, both the measurement and the calibration are checked for failure. Failures are indicated in the display and via the alarm relay, which can set off a horn or lamp or relate to a central control. If that failure makes control unreliable, the controller is automatically switched off until the failure has been taken care off.

CAUTION **The instrument checks the input signals, the calibration results, and the water flow, if a flow sensor is connected. It cannot detect erroneous settings or failures in the treatment system, nor can it check for plausibility! The safety of the system of which the instrument is part of, lies within the reach of responsibility of whoever built the system.**

1.3 Intended use

Use these instruments only for the monitoring and control of water.

Use only sensors, fittings, and accessories fit for your application.

Ensure that the required measuring conditions are constantly maintained, such as flow, pressure, temperature, etc.

Set-up the instrument according to this manual. Carry out all the steps described, and check all measurements and settings before you activate the controller.

Use all available safety measures such as the alarm relay, the dosage check, and the lack-of-water indication.

Regularly check that all safety measures are in good working order.

CAUTION **The protection built into the instrument is impaired if they are not used as intended!**

1.4 Features

Meter

Measuring ranges	0.00 - 14.00 pH -1500 - 1500 mV -30.0 - 140.0 °C
Display	Measured value with dimension Temperature with dimension Status display sensor, calibration, controller & alarm
Temperature compensation	manual or automatic with Pt100
Calibration	automatic recognition of the calibration solutions in arbitrary order



Controller

Set points	2 set points with adjustable direction
Controller types	ON/OFF controller with hysteresis P controller as Pulse-Pause-, Impulse-Frequency- or steady controller PI controller as Pulse-Pause-, Impulse-Frequency- or steady controller
Hysteresis	adjustable within the measuring range
P range X_p	adjustable within the measuring range
Integral time T_N	0 - 2000 sec.
Least pulse	0.1 - 9.9 sec.
Pulse+Pause time	02 - 99 sec.
Impulse frequency	100 - 7200 pulses/h
Turn-on delay	0 - 200 sec.
Dosage check	0 - 90 min
Alarm function	min. and max. limit and onset delay

Connections

Relays	3 potential-free contacts (2x controller, 1x alarm) 6 A, 250 V, max. 550 VA
Analog output	0/4-20 mA galvanically isolated, max. loading 500 Ohm
Analog inputs	1 measuring input for pH or ORP 1 measuring input for temperature sensor Pt100
Digital input	external controller stop or low water indication NC or NO selectable via menu
Serial interface (Option)	RS485, Baud rate 9600, data format 8Bit, 1start and 1stop bit, no parity

1.5 Technical data

Feature	K 100	K 100 W
view		
Installation	panel-type housing	wall-mounting housing
Dimensions	96 x 96 x 135 mm (WxHxD)	165 x 160 x 85 mm
Weight	0.8 kg	1.0 kg
Terminals	screw terminals for cables up to 1.5mm ²	spring-loaded terminals for cables up to 1.5mm ²
Protection class	Front IP54	IP65
Power supply	230 V +/-10%, 40..60 Hz, optionally 117 V or 24 V	
internal fuse	none	230V: 63mA HRC 117V: 125mA HRC 24V: 800mA NRC
Power consumption	10VA	
Contact rating	6 A/ 250 V, max. 550 VA resistive load (with RC protective circuit)	
Operation temperature	0 - 50°C	
Storage temperature	-20 - +65°C	
Humidity	max. 90% at 40°C non condensing	

2. Instructions for installation and connections

Installation:

On the next pages you will find detailed instructions for the installation.

For panel-type meters you have to prepare an opening of 92x92mm. Install the instrument and fix it with the two mounting clips which were part of the delivery.

You can install instruments in wall-mounting housings either by hanging them upon the center slot or by sliding the slot under a screw, which is an alternative for limited space. Either way you have to fix it additionally with two screws.

ATTENTION Install the instrument in a place where it is not put under mechanical or chemical strain!

Mind the protection class:

K 100: Front IP54

K 100 W: IP65 (closed terminal cover)

Connections:

You will find detailed connection diagrams on the following pages.

Before connecting the power supply check the information on the instrument label!

ATTENTION Input, output and control lines must be installed separate from each other and separate from power lines!

For inputs and outputs use screened lines and connect the screen on one side only.

The measurements are interference-sensitive. Special screened cables with a very high insulation over short distances, and an impedance converter for longer connections.

For the connection of temperature sensors use a low-resistance cable with a large diameter.

When using the relays, mind that with inductive loads, interference must be suppressed. If that is not possible, the relay must be protected at the terminal block in the K 100 by a resistance-capacitance filter or, in case of direct current, by a free-wheeling diode.

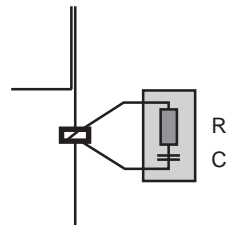

Current up to	Capacitor C	Resistance R
60 mA	10 nF 260 V	390 Ohm 2 Watt
70 mA	47 nF 260 V	22 Ohm 2 Watt
150 mA	100 nF 260 V	47 Ohm 2 Watt
1,0 A	220 nF 260 V	47 Ohm 2 Watt

2.1 Dimensions

K 100

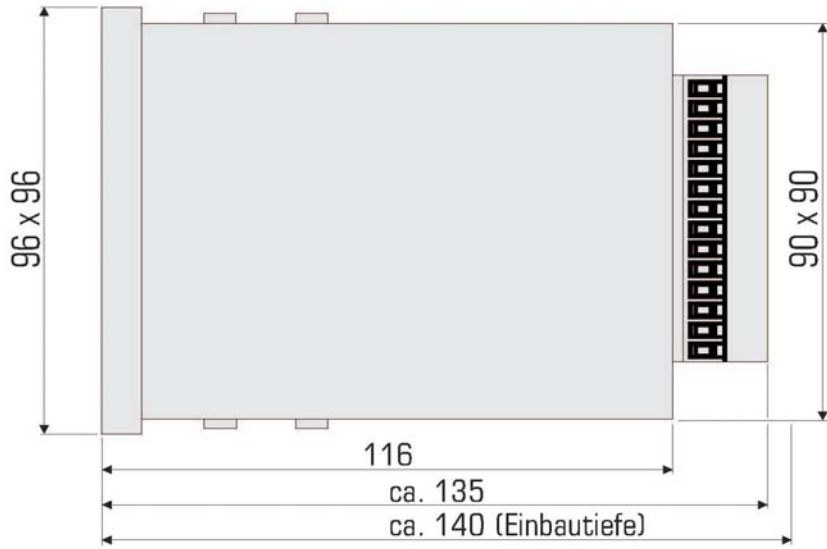

K 100 W

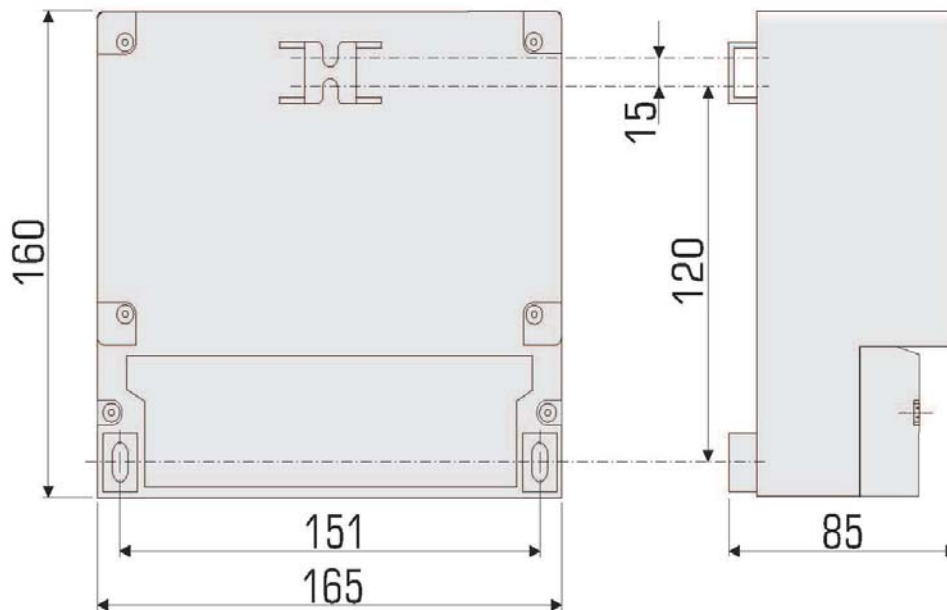

2.2 Installation K 100

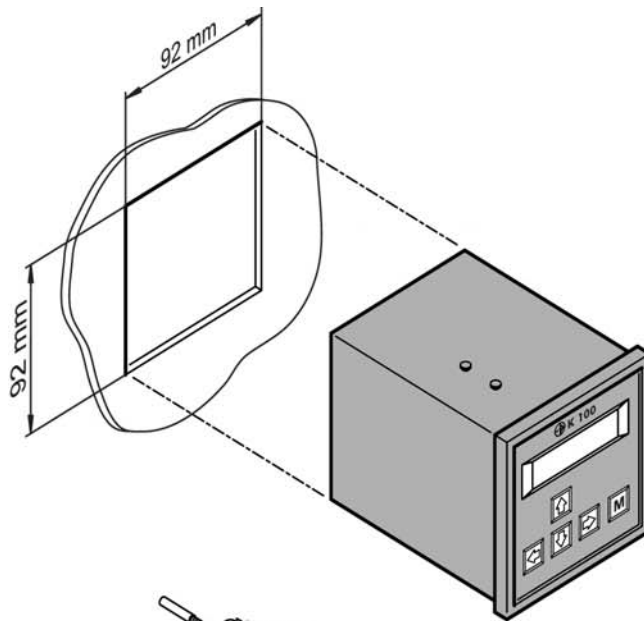

Prepare an opening of 92 x 92 mm.

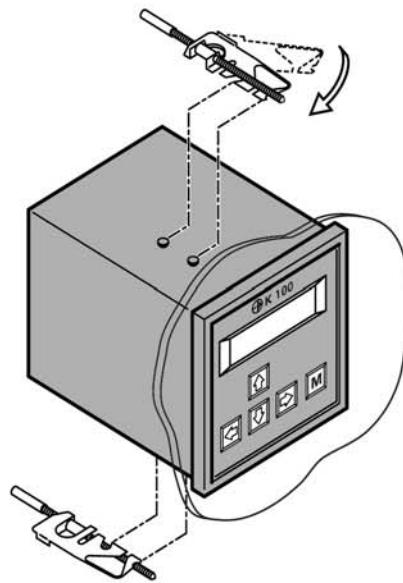

Install the instrument from the front side and fix it with the two mounting clips which were part of the delivery.

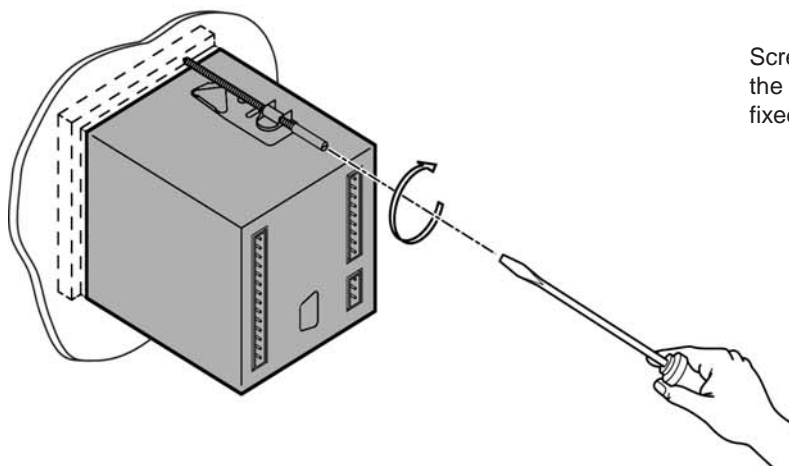

Screw tight until the instrument is fixed perfectly.

2.3 Installation K 100 W

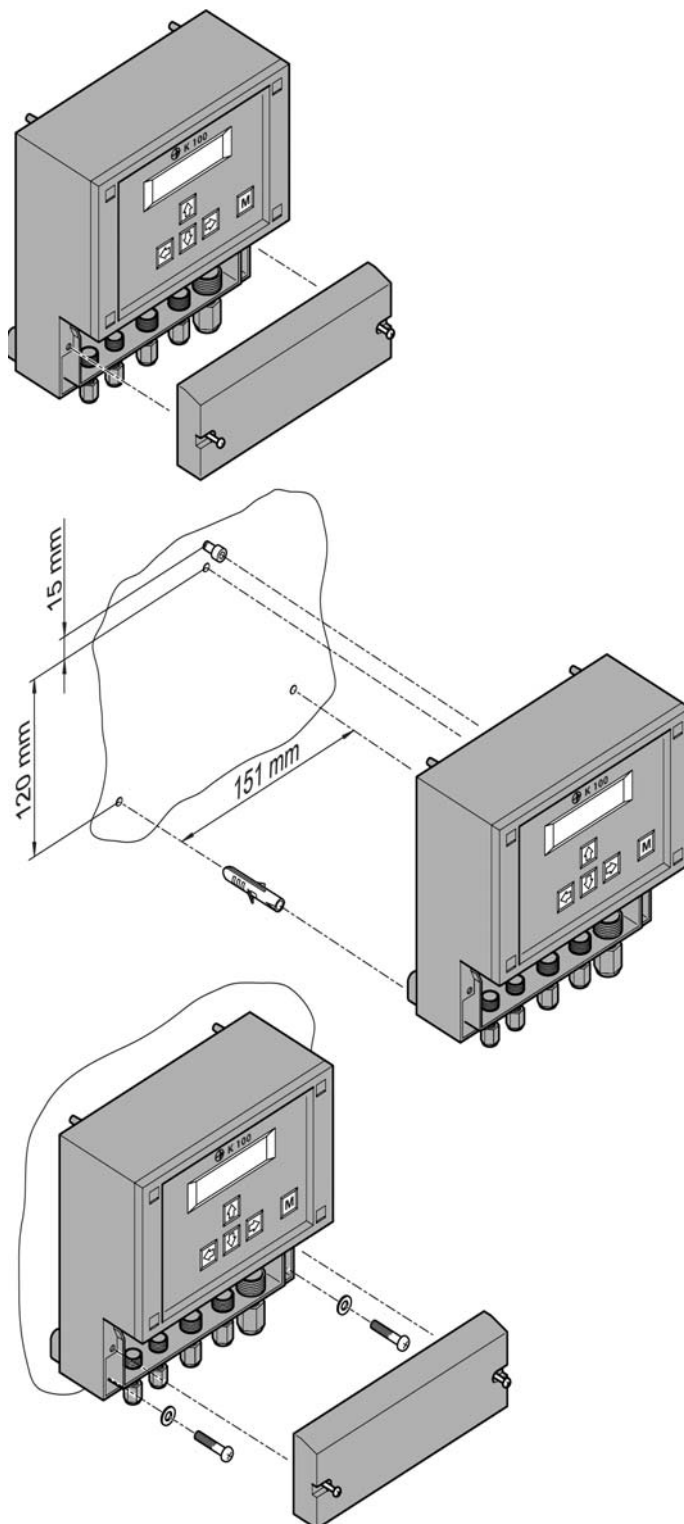

Remove the terminal cover.

Drill three holes (max. M5) according to the drawing. Mind that there are two ways for installation: (1) You can hang the instrument upon the upper screw. In that case drill the upper hole 120mm above the lower two. (2) Or you can slip the fixture on the back of the instrument under the upper screw. In that case the upper hole has to be another 15mm higher.

Mount the instrument and fix it with the two lower screws. Close the terminal cover or start with the connections.

2.4 Connection diagram K 100

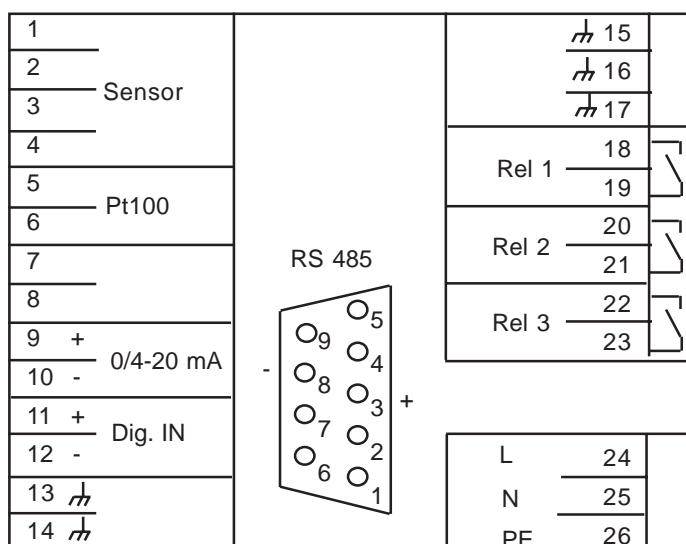
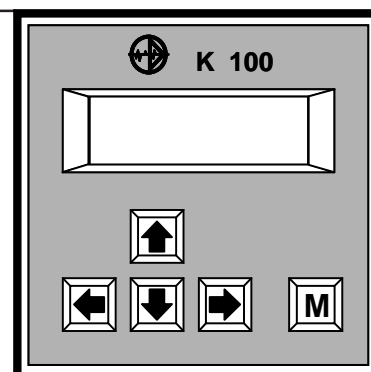

Connection	Terminals	Note
pH sensor	1 + 2	1 = Reference electrode = screen 2 = Measuring electrode = core
with impedance converter	1 - 4	Measurement = brown & white 1 = brown, 2 = white Supplied voltage = yellow & green 3 = yellow = - 6 V 4 = green = + 6 V
ORP sensor	1 + 2	1 = Measuring electrode = core 2 = Reference electrode = screen
Pt100	5 + 6	
Analog output	9 + 10	9 = +, 10 = -, max. load 500 Ohm
Digital input	11 + 12	11 = +, 12 = -, external controller stop and / or low water indication
Relay 1	18 + 19	
Relay 2	20 + 21	
Relay 3	22 + 23	Alarm relay
Power supply	24 - 26	Check information on instrument label!
RS485 (Option)	Sub-D	3 = +, 8 = - 4/7 bridged activates terminating resistance

2.5 Connection diagram K 100 W

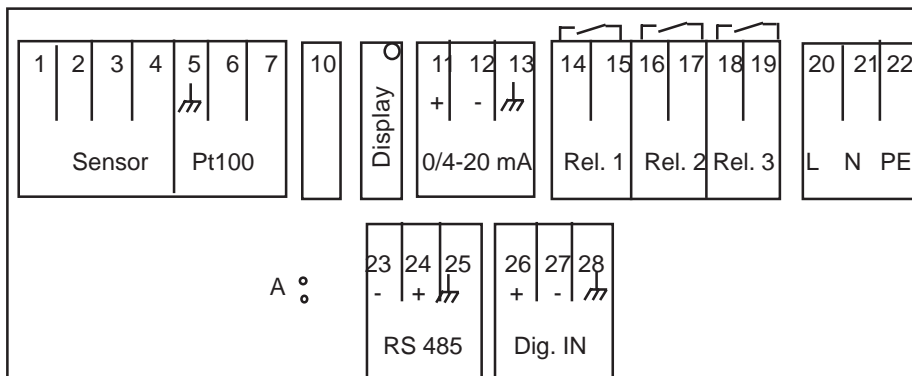
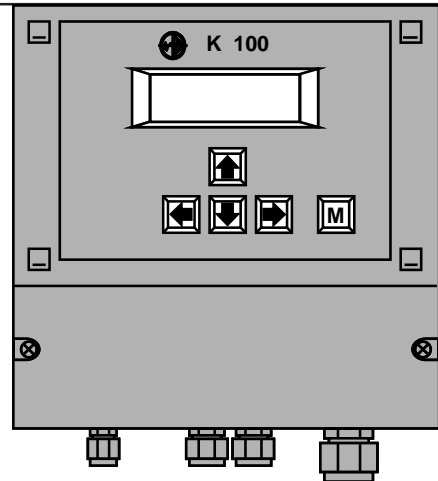

Connection	terminals	Note
pH sensor	1 + 2	1 = reference electrode = screen 2 = measuring electrode = core
with impedance converter	1 - 4	Measurement = brown & white 1 = brown, 2 = white Supplied voltage = yellow & green 3 = yellow = -6V 4 = green = +6V
ORP sensor	1 + 2	1 = measuring electrode = core 2 = reference electrode = screen
Pt100	6 + 7	
Display contrast	Display	Potentiometer to adjust brightness
Analog output	11 + 12	11 = +, 12 = -, max. load 500 Ohm
Relay 1	14 + 15	
Relay 2	16 + 17	
Relay 3	18 + 19	Alarm relay
Power supply	20 - 22	Check information on instrument label!
RS485 (Option)	23 + 24	23 = -, 24 = + Jumper A activates terminating resistance
Digital input	26 + 27	26 = +, 27 = -, external controller stop

3. Operation of the instrument

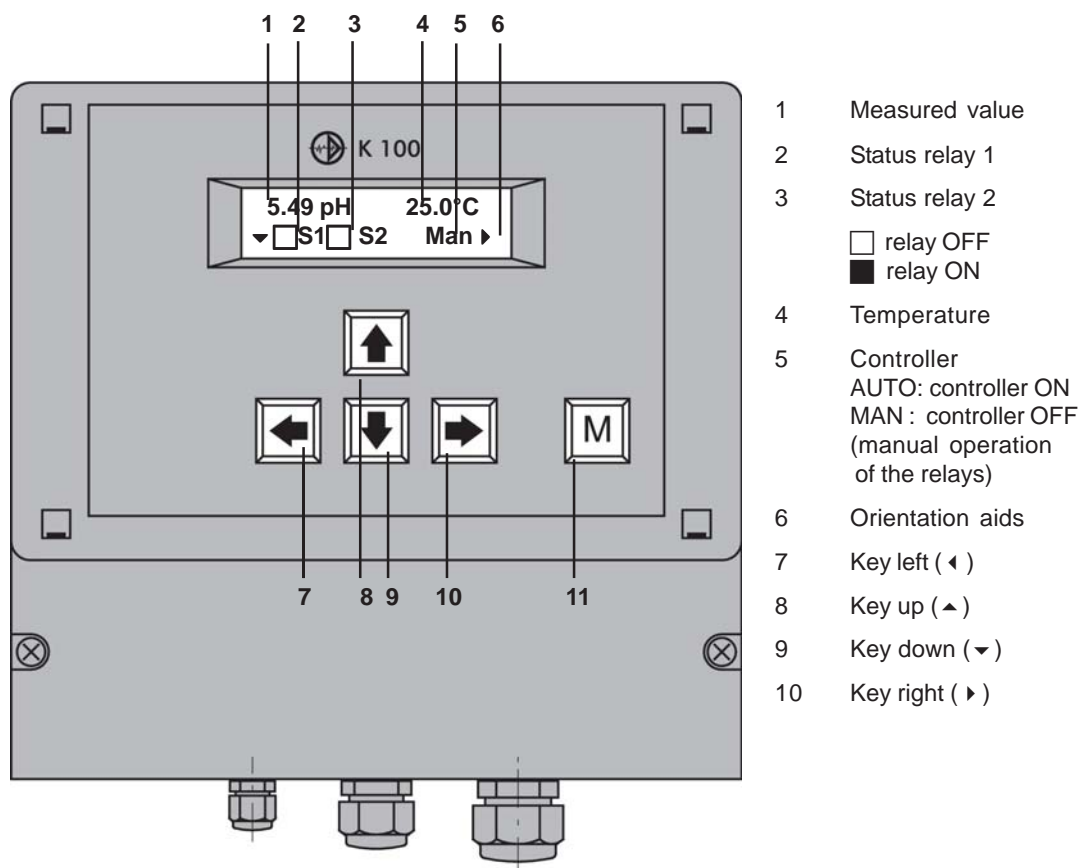

When turned on the instrument shows the measured value and temperature together with the controller mode (Man) and the status of the relays S1 and S2 (both OFF).

With five membrane keys you can move within the menu:

With key ▼ you enter the main menu.

With keys ▲ and ▼ you move up and down in the menu.

With key ▶ you address a menu or parameter.

With key ◀ you leave a menu or store a change.

For your convenience triangles in the display indicate the directions you can take from your position in the menu.

With key „M“ you get back to the display of the measured values from any point in the menu. Changes that have not been stored will be lost.

NOTE **The instruments K 100 and K 100 W differ only in the enclosures. Operation and menus are the same.**

3.1 How to adjust parameters

Temp. Comp.
▶ Manual Comp.

1) When you address a parameter the actual setting is displayed.

Temp. Comp.
▶ Automat. Comp.

2) Switch to the next alternative setting with key ▶ .

Temp. Comp.
▶ Manual Comp.

3) When you have come to the last alternative, pressing the key once more will bring you back to the start.

Selection between alternatives

For many parameters you have the choice between two or more alternatives, e. g. between manual and automatic temperature compensation. For these parameters you need only key ▶ . Switch from one alternative to the next until you either come back to where you started or until you reach the alternative you were looking for.

With these parameters any changes are immediately valid - there is no need to store the change.

Enter code
▶ 058 Code

1) Address the parameter with key ▶ .

Enter code
◀ 058 Code

2) A double triangle appears behind the number indicating that the number can be changed now with keys ▲ and ▼ .

Enter code
▶ 062 Code

3) Store the new value with key ◀ . The double triangle disappears - the new value is stored.

Adjustment of numerical parameters

Numerical parameters can only be altered when a double triangle is visible behind the number. This double triangle appears when you address the parameter with key ▶ .

Adjust the parameter with keys ▲ and ▼ . A short pressure on the key changes the last decimal by 1. If you keep the key pressed, the value will continue changing until the pressure is released.

Store the changes with key ◀ . The double triangle disappears.

NOTE If you do not want to store the change, press key „M“ instead of key ◀ .

3.2 Where to look for information

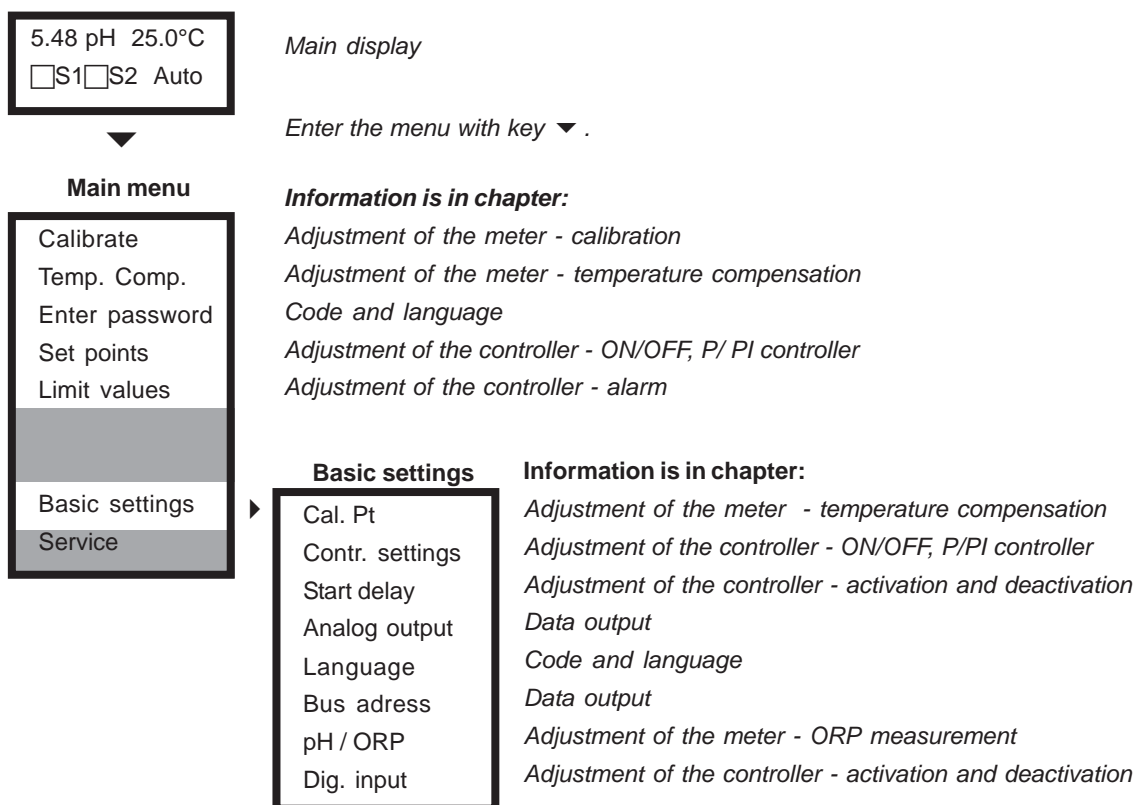

Main menu and basic settings

The parameters are sorted into two menus: In the main menu you will find all functions which are used regularly, such as calibration. The menu basic settings contains all parameters which are set just once during start-up.

On the following pages you will find information on how to adjust parameters and which parameters you need for which application, in the following order:

- 1) General adjustments: password and language
- 2) Adjustments for measurement: calibration and temperature compensation for pH or selection of ORP measurement
- 3) Adjustments of the controller: selection of the controller version and corresponding parameters
- 4) Adjustments to read out data: analog, digitally and/or as alarm

3.3 Menu overview

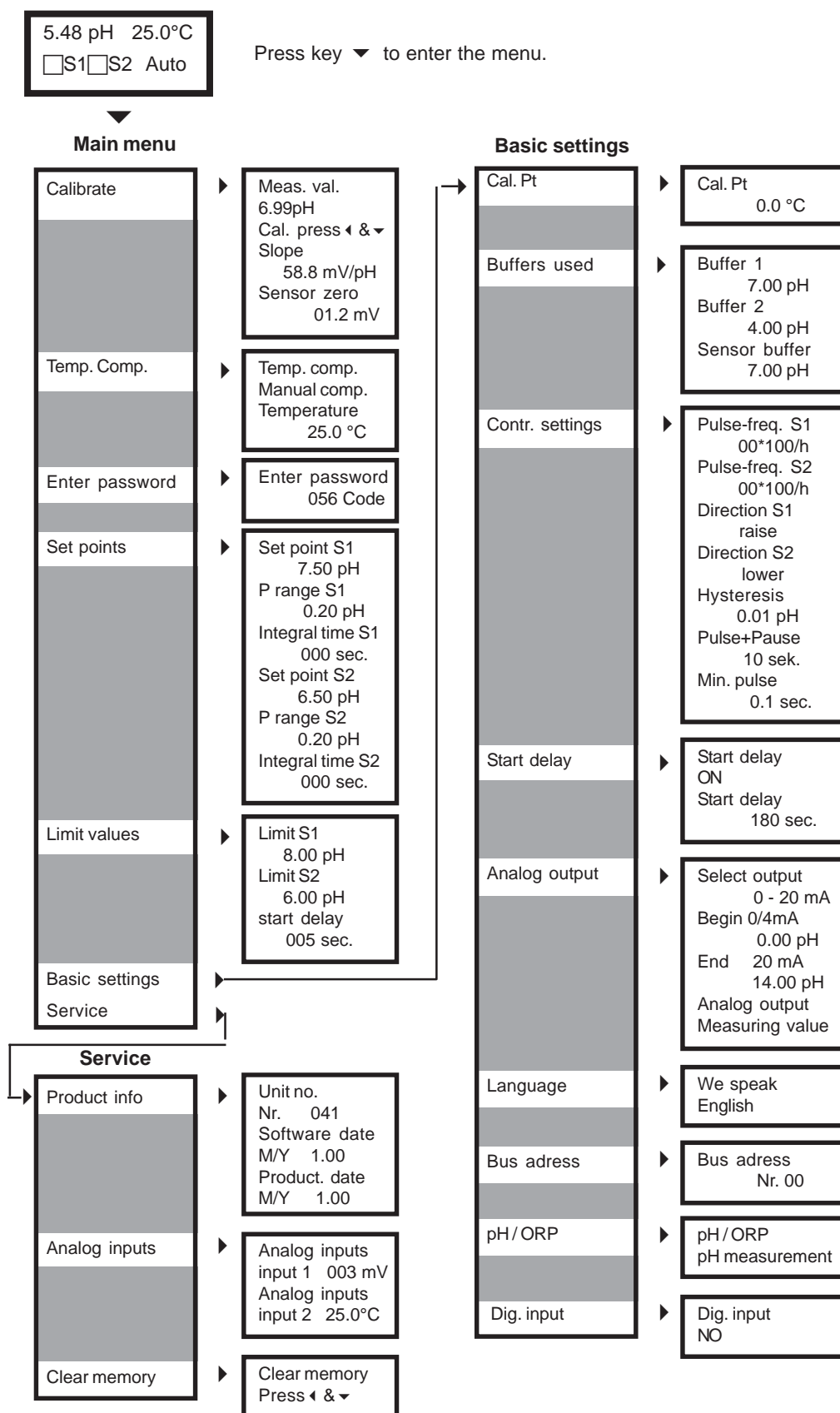

4. Code and language

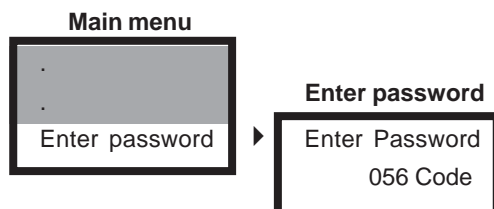

Enter password

To get access to the various parameters you have to enter the correct password:

Code 11 gives access to the parameters „calibration“, „temperature compensation“, and „set points“.

Code 86 gives access to all parameters and functions.

With any other number it is impossible to select, view or change any parameter.

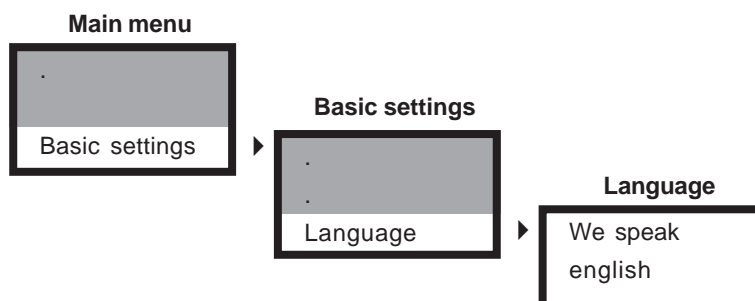

Language

For the communication with the instrument you can choose from a variety of languages.

Since choosing a language is part of the basic settings, it requires code 86. If a different code is set, you will be asked to enter the correct password.

5. Adjustments for measurement

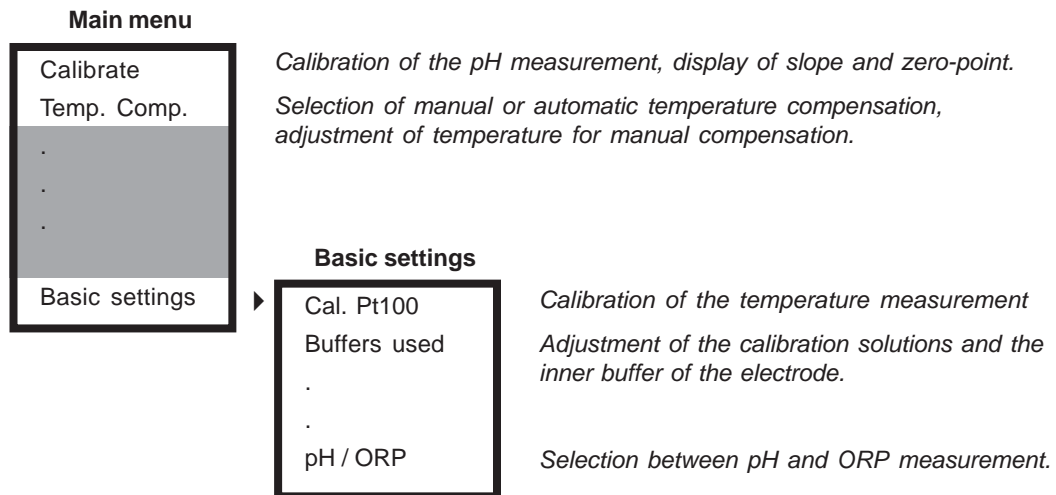

The instruments K 100 PR and K 100 W PR can be used for pH or ORP measurements.

pH measurement

pH measurement requires a calibration.

By means of calibration the electrode's characteristics are determined and stored. The procedure is a subsequent measurement of two solutions with a known pH. The pH values of the buffers used asd calibration solutions are stored in the menu basic settings.

You have to adjust the calibration data only if you want to use special calibration solutions or electrodes with a special buffer solution.

The electrode's slope is influenced by temperature. This influence can be compensated by manual or automatic compensation. Manual compensation means that the temperature is entered manually. Automatic compensation requires measuring the temperature with a Pt100.

ORP measurement

At works the instruments are set for pH measurement. For ORP measurements you have to switch to ORP measurement.

This is the only adjustment. ORP measurements do not require calibration or temperature compensation. Therefor the parameters „calibration“ and „temperature compensation“ do not appear in the menu if ORP measurement has been selected.

5.1 Calibration

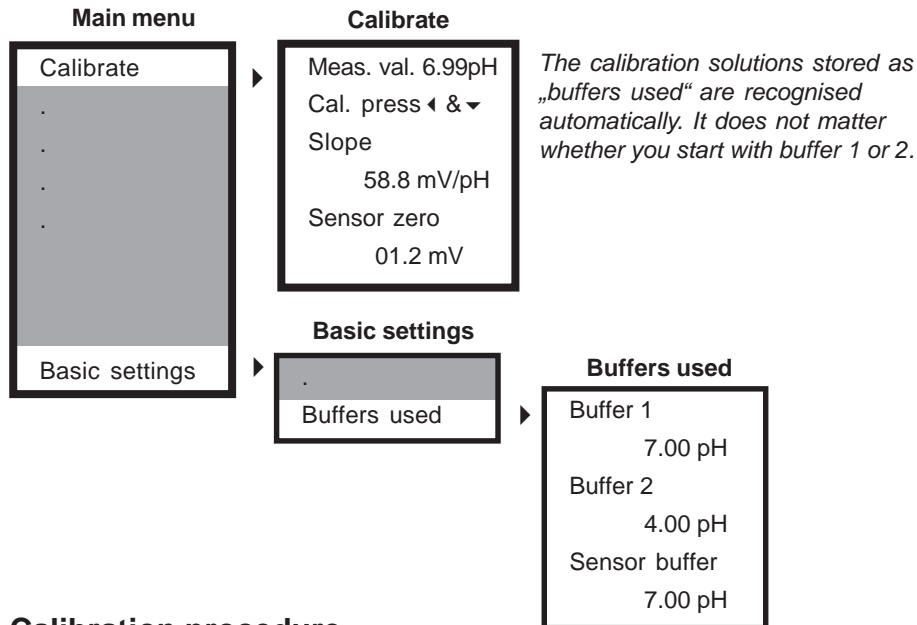

Calibration procedure

- 1) Switch the controller OFF and select manual temperature compensation. Enter the temperature of the calibration solutions.
- 2) Immerse the electrode in one of the calibration solutions. Wait until the measured value is stable, then calibrate by pressing keys ◀ and - while still applying pressure - additionally key ▼. The pH of the calibration solution is now displayed as measured value.
- 3) Rinse the electrode and repeat step 2 with the second calibration solution.
- 4) Check the slope and sensor zero-point, then put the electrode back into the armature. Select automatic temperature compensation and switch ON the controller.

NOTE The slope should be close to 59 mV, the zero-point close to 0 mV. The slope decreases and the zero error increases with time. When either value exceeds certain limits, the instrument displays an error message indicating that the electrode has to be replaced.

Buffers

At works the following buffers are stored:

Calibration solutions: buffer solutions pH 4 and pH 7
 Inner buffer of the electrode: pH 7

If you want to use other calibration solutions, adjust the values - it does not matter if you start with the higher or the lower pH.

If you are using electrodes with a special inner buffer, adjust the pH value of the sensor buffer, since this value is used as zero for the calculation of the measured values. You will find the pH of the sensor buffer printed on the electrode.

5.2 Temperature compensation

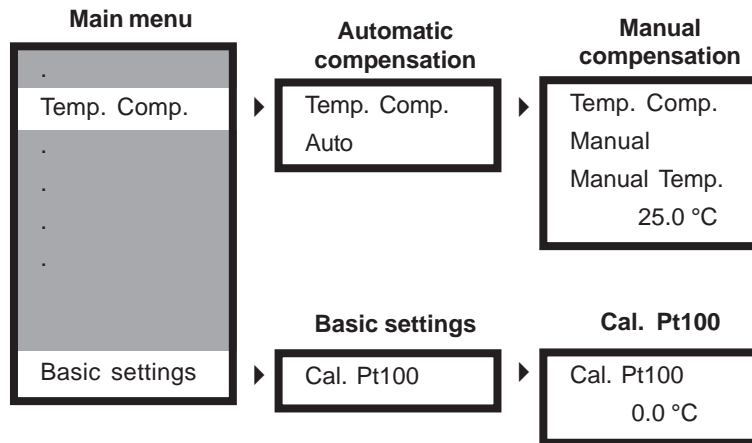

Choose between two types of temperature compensation:

- 1) Automatic compensation with temperature sensor Pt100

Mind that the temperature sensor should measure the temperature in the vicinity of the pH sensor. If temperature sensor and pH sensor are not immersed in the same solution, as for e. g. during calibration, better switch to manual compensation.

- 2) Manual compensation

If the temperature is more or less stable you can enter it manually. The instrument will then compensate the temperature effect of this temperature.

Calibration of the temperature measurement

Since the temperature sensor is connected with a twin-core cable, slight deviations might occur between measured and real temperature. These deviations can be eliminated by calibration.

During start-up, measure the temperature manually and enter a correction term so that the display shows the exact temperature.

5.3 ORP measurements

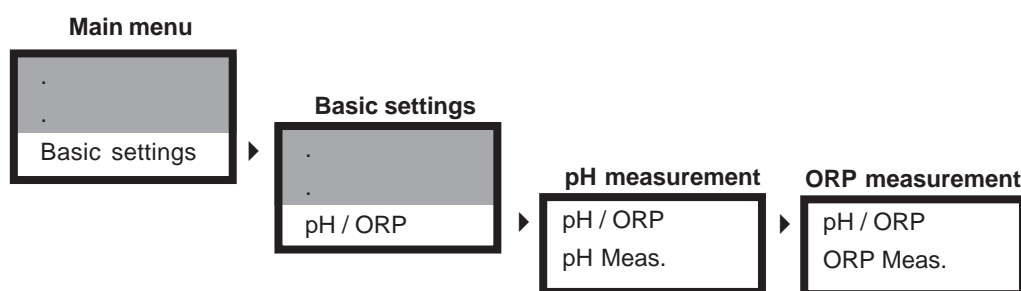

At-works the instruments are set to pH measurement. For ORP measurement you have to switch to ORP measurement. Select the parameter „pH / ORP“ of the basic settings and switch to ORP by pressing key ▶ .

The actual setting is indicated when you select the parameter.

Switch back to pH measurement

If the instrument is set to ORP measurement, switch back to pH measurement by pressing key ▶ .

6. Adjustment of the controller

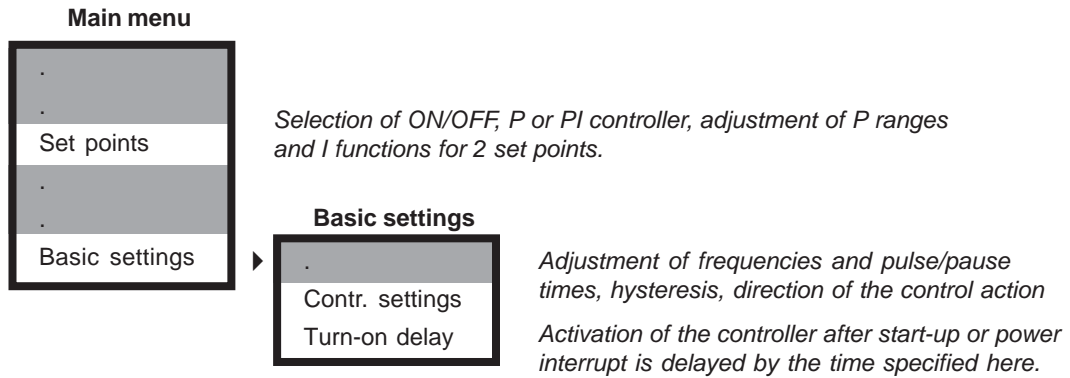

For any type of controller you have to enter one or two set points, and you have to tell the instrument whether these set points are reached by increasing or decreasing the measured value.

You can choose between three different controller versions:

ON/OFF controller

The ON/OFF controller switches ON if the measured value exceeds the set point and OFF if it drops back below it or vice versa. Dosage is always carried out with 100% (ON) or 0% (OFF). The parameter for an ON/OFF controller is the hysteresis.

P controller

The P controller or proportional controller reduces the dosage in the vicinity of the set point proportional to the control deviation. This is easily achieved if the analog output is used as steady control output. If the relays are used, the proportional reduction is achieved by either reducing the switch frequency (Impulse-frequency controller) or reducing the time within a given period of time in which the relay is ON (pulse-pause controller). The parameters for a P controller are the P range and the impulse-frequency or the pulse+pause time and the minimum pulse.

PI controller

The PI controller is a P controller with an additional I function. Adjustments and parameters are the same as for an P controller. Additionally the integral action time has to be adjusted which determines the I function. The I function eliminates the P controller's disadvantage of a remaining steady-state deviation.

6.1 ON/OFF controller

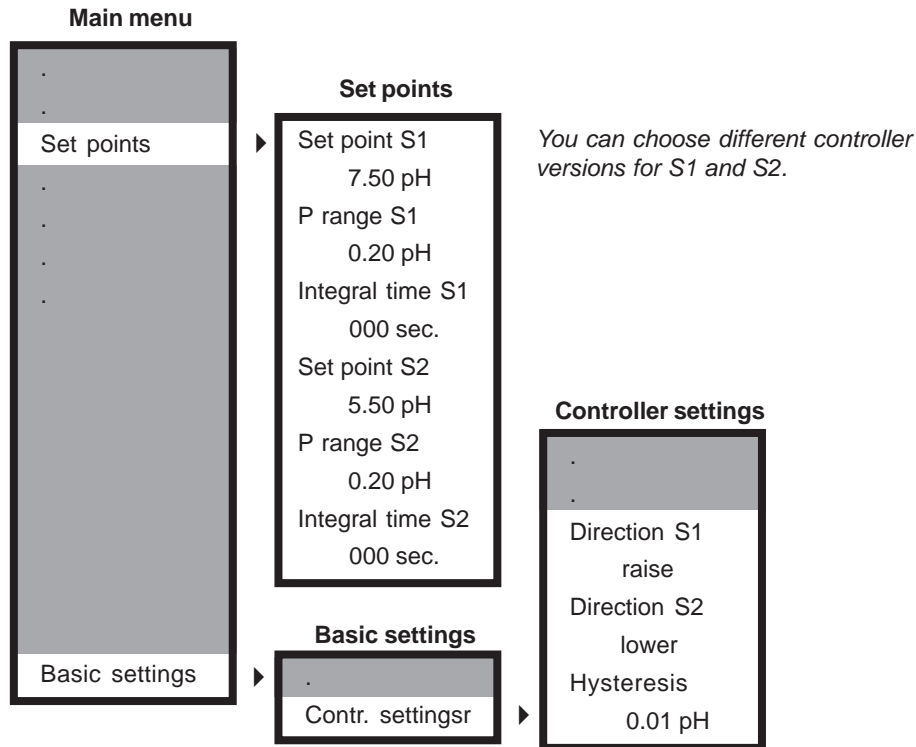

For an ON/OFF controller you have to set the following parameters:

1) Set points S1 and S2

Set point S1 refers to relay 1, set point S2 refers to relay 2.

2) P range and integral action time for S1 and S2

For an ON/OFF controller set P range = 0 and integral time = 0.

3) Acting direction for S1 and S2

Select „raise“ if the dosage raises the measured value.
Select „lower“ if the dosage lowers the measured value.

4) optionally a hysteresis

The hysteresis prevents fast switching in the vicinity of the set point. If hysteresis is activated (by setting a value > 0) the relay switches only when the set point is exceeded by half the hysteresis.

6.2 P / PI controller as impulse-frequency controller

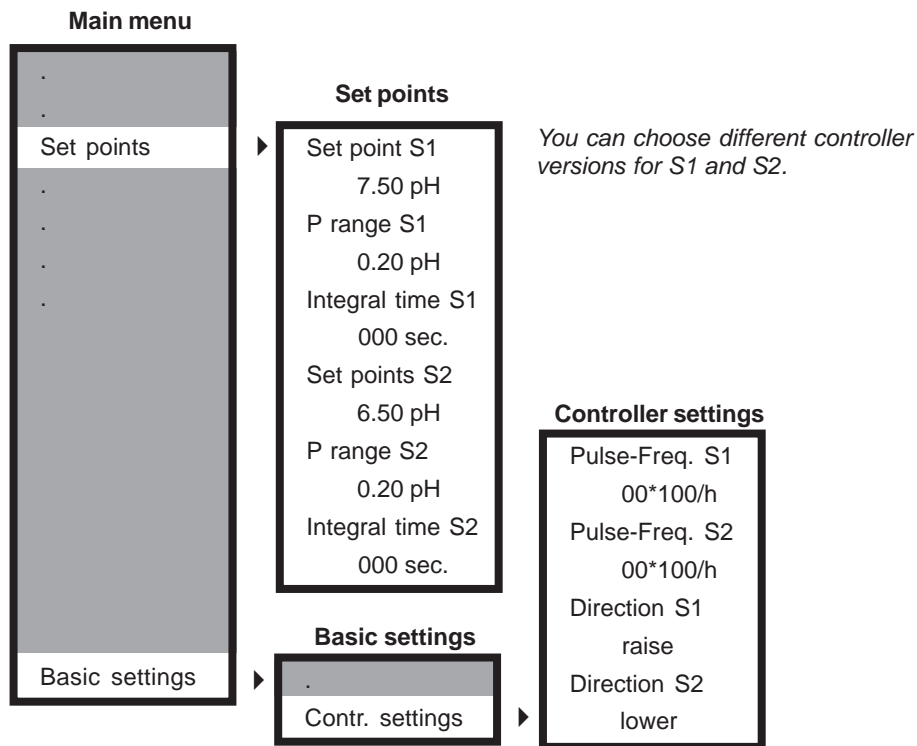

For an impulse-frequency controller you have to set the following parameters:

1) set points S1 and S2

S1 refers to relay 1, S2 refers to relay 2.

2) P range and integral action time for S1 and S2

Adjust a P range > 0. For a P controller set integral time = 0, for a PI controller set an integral time > 0.

3) pulse-frequencies for S1 and S2

Enter the maximum pulse-frequency that corresponds to 100% dosage.

4) the acting direction for S1 and S2

Select „raise“ if the dosage raises the measured value.

Select „lower“ if the dosage lowers the measured value.

6.3 P / PI controller as pulse-pause controller

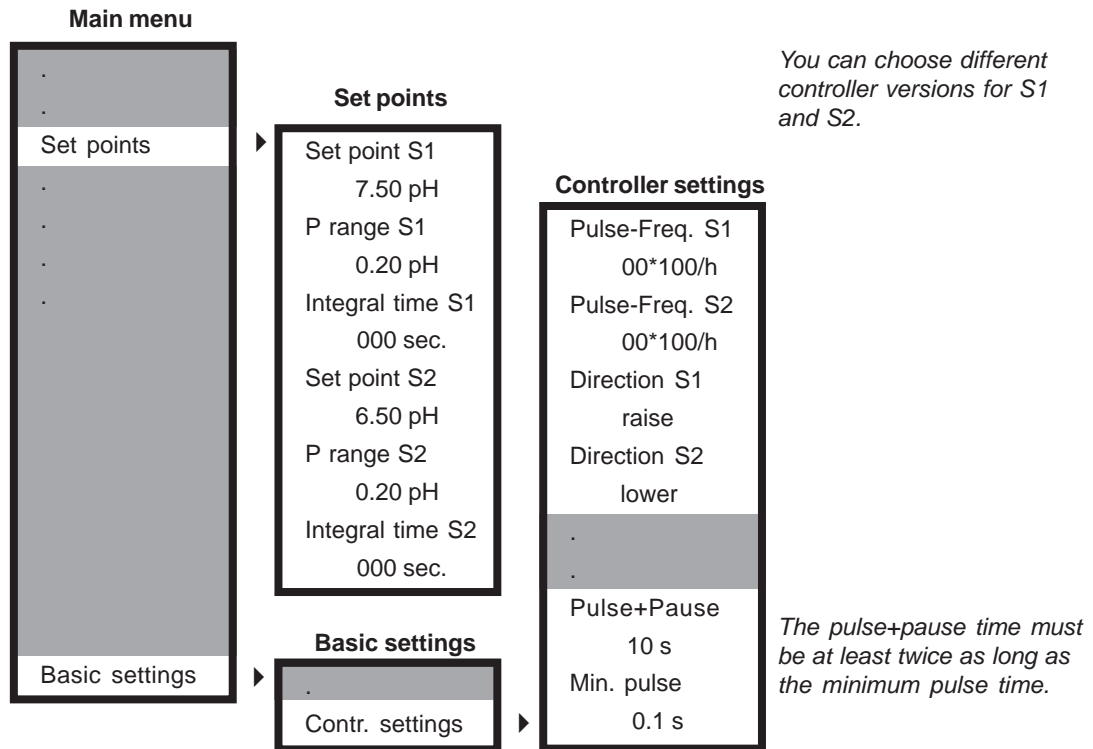

For a pulse-pause controller you have to set the following parameters:

1) set points S1 and S2

S1 refers to relay 1, S2 refers to relay 2.

2) P range and integral action time

Adjust a P range > 0. For a P controller set integral time = 0, for a PI controller set an integral time > 0.

3) pulse-frequencies for S1 and S2

Both frequencies must be set to 00, otherwise the controller will act as an impulse-frequency controller.

4) the acting direction for S1 and S2

Select „raise“ if the dosage raises the measured value.
Select „lower“ if the dosage lowers the measured value.

5) pulse+pause time

Define a period of time during which the relay is proportionally to the control deviation ON (pulse) or OFF (pause), respectively.

6) least pulse time

Set a minimum pulse time that the relay has to at least remain open to allow the actuator to react.

6.4 Activation and deactivation of the controller

You can activate and deactivate the controller without any menu. Press key ▶ to switch between manual operation (controller OFF) and automatic operation (controller ON). The actual operation mode is indicated in the display by MAN or AUTO.

WARNING Make sure that the controller is OFF when connecting dosing pumps or other actuators!

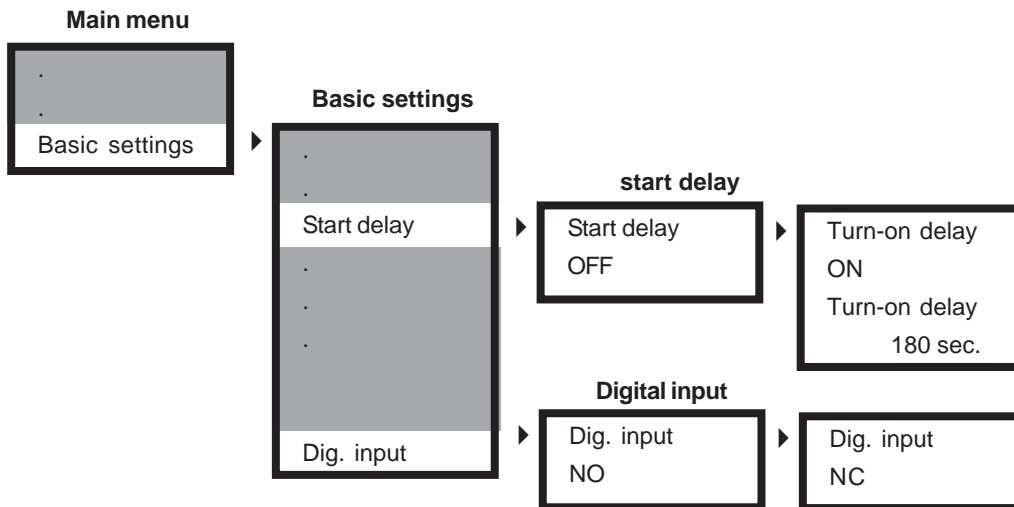

6.5 Turn-on delay

Set a delay time which has to pass before the controller is activated after start-up or power interrupt. This allows the measurement to settle and prevents inappropriate dosage of chemicals.

6.6 External controller stop (digital input)

You can activate or deactivate the controller with an external switch by using the digital input. This feature can also be used as low water indication. Just connect a level or flow sensor to the digital input. At works, the input ist NO (normally open). You can switch to NC (normally closed) in the basic settings.

With selection NO, the controller stops whenever the digital input is closed, with NC, it stops whenever the input is opened.

As long as that is the case, the message "external controller stop" is displayed.

6.7 Manual operation of the relays

5.48 pH 25.0°C ▼ □S1 □S2 Auto ▶	1) If the controller is ON, switch it OFF with key ▶ . Instead of „Auto“ the display shows „Man“.
5.48 pH 25.0°C ◆▶ □S1 □S2 Man ▶	2) Switch to the operation mode of S1 with key ▲ . The square to the left of S1 starts to flash.
5.48 pH 25.0°C ◆▶ □S1 □S2 Man ▶	3) Switch ON relay 1 with key ▶ . The square to the left of S1 gets dark.
5.48 pH 25.0°C ◆▶ ■S1 □S2 Man ▶	4) Switch OFF relay 1 again with key ▶ . The square gets light.
5.48 pH 25.0°C ◆▶ □S1 □S2 Man ▶	5) Switch to the operation mode of S2 with key ▲ . The square to the left of S2 starts to flash.
5.48 pH 25.0°C ◆▶ □S1 □S2 Man ▶	6) Switch ON relay 2 with key ▶ . The square to the left of S2 gets dark.
5.48 pH 25.0°C ◆▶ □S1 ■S2 Man ▶	7) Switch OFF relay 2 again with key ▶ . The square gets light.
5.48 pH 25.0°C ◆▶ □S1 □S2 Man ▶	8) Leave the operation mode of relay 2 with key ▲ . Both squares appear light, none flashes - You have left the operation mode.
5.48 pH 25.0°C ◆▶ □S1 □S2 Man ▶	

For manual operation you need no menu.

With key ▶ you switch OFF the controller.

With key ▲ you switch between Manual operation <> operation mode S1 <> operation mode S2 <> manual operation.

In the operation mode you can Switch ON and OFF the selected relay with key ▶ .

A flashing square indicates that the relay is in operation mode.

A dark square indicates that the relay is switched ON.

A light square indicates that the relay is switched OFF.

WARNING If you switch ON a relay it stays ON until you switch it OFF again manually!

6.8 Limit values and Alarm

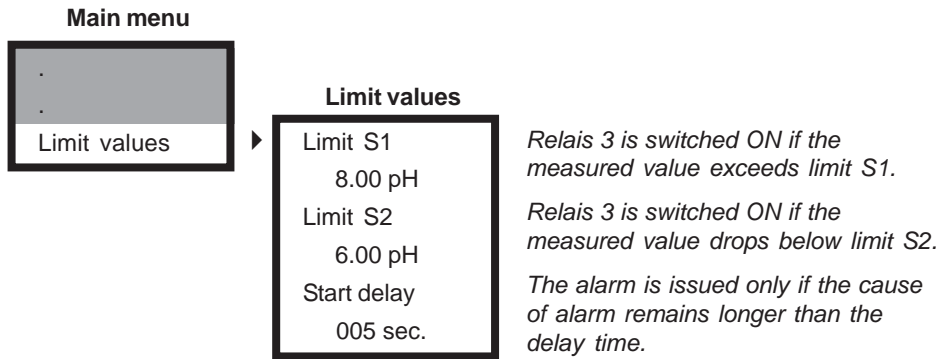

For the alarm, you can adjust two limits: limit 1 is an upper limit. If the measured value exceeds limit 1, an alarm is issued. Limit 2 is a lower limit. The alarm is issued if the measured value drops below limit 2.

In case of alarm the display shows the message „limit 1“ (or 2, respectively), and relay 3 is switched ON. This relay can be used to activate an external horn or lamp.

NOTE **The alarm function is only active when the controller is set on automatic mode. When you switch the controller to MAN, the alarm is extinguished.**

Start delay

In some applications it happens regularly that the measured value exceeds a limit for a short period of time. To avoid having an alarm issued under these circumstances you can adjust a start delay which has to pass before an alarm is issued. If the start delay time is >0 then the alarm is issued only if the cause of alarm remains longer than the specified delay time.

6.9 Dosage check

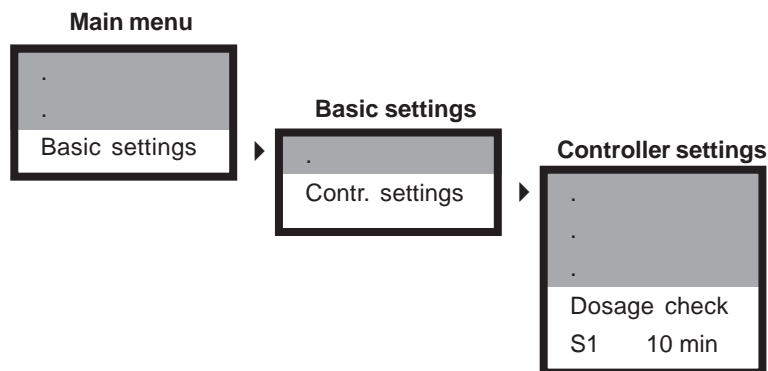

In the basic settings of the controller you can define, how long a controller is supposed to dose with 100% without raising alarm.

If the controller output is 100% for more than the specified time, this is interpreted as an indication of failure, and the instrument issues an alarm and deactivates the controller, thus stopping further dosage.

The dosage check is a safety catch to prevent hazardous chemicals to be set free in case of a defective dosing tube or tube connection.

NOTE In case of an alarm due to dosage check, only the controller concerned is deactivated.

NOTE If you set the dosage check time to 0 seconds, the dosage check function is deactivated.

7. Data output

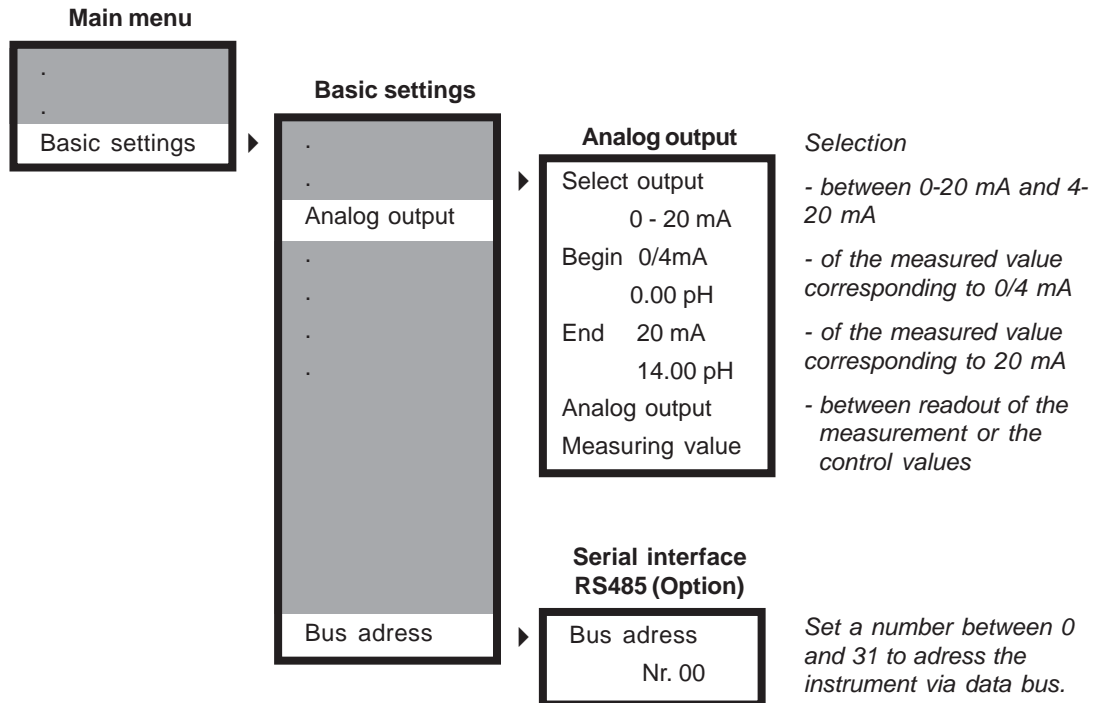

7.1 Current output

You can read out the measured values as 0/4-20 mA signals via the current output. With the setting 4-20 mA the resolution is lower, but defective cable connections are immediately evident.

With the parameters Begin and End you define which part of the measuring range you want to read out.

7.2 Current output as controller output

Alternatively you can use the current output as steady-state controller output. In that case assign the current output to the correcting variables S1 bzw. S2 instead of the measured value. The output will be in % - 100% equalling 20mA - so you do not have to define start and end values.

7.3 Serial interface RS485 (option)

The instruments are available with serial interface RS485 by means of which they can be integrated in a data bus system. Via the interface, all settings, measured and control values as well as any error messages can be read out digitally.

Instruments with RS485 are automatically delivered with the leaflet „Information on the RS485“ which contains instructions on the communication and a complete list of the functions available via interface.

8. Operation and maintenance

Display contrast

With instruments in wall-mounting enclosures the display contrast can be adjusted to the actual light conditions by means of a potentiometer. It is indicated in the connection diagram with the word „display“.

Cleaning

The front and the display should not get in touch with organic solutions such as methanol. Never let water get inside the instrument. We suggest to simply use a damp cloth for cleaning.

Exchange fuse

WARNING! Disconnect the power supply before opening the instrument!

ATTENTION Mind that the cable connections to the front are not damaged, broken or torn during the process!

Instruments in wall-mounting enclosures have an internal fuse which has to be replaced at need. You will find a spare fuse fixed to the inside of the terminal cover. Information on the fuse can be found in the chapter „Technical data“.

To exchange the fuse, open the front carefully. The fuse is located in the lower right hand side. It is kept in place by a Bayonet lock. Turn the lock to the left until the fuse pops up. Exchange it and fix the new fuse by turning the lock to the right. Put the front back on and fix it tightly.

Maintenance of the safety functions

Regularly check the alarm relay to make sure that in case of failure both the indication by the instrument and the recognition by the superior control (SPS etc.) work reliably.

You can set off the alarm for example by setting limit S1 to a value smaller than the current measured value.

NOTE Mind that perhaps an alarm delay has been set. Also remember to restore the original settings after the test!

Regularly check the function of the water level or flow sensor to make sure that in case of lack of water the sensor gives the signal that leads to the controller stop.

Simulate lack of water by briefly interrupting the water supply. This must lead to a switch of the level sensor or a decrease of the flow signal, and the message „ext. controller stop“ or „no water“ must appear in the display.

Maintenance of the measurement

Regularly clean the metallic surfaces of the ORP electrodes with a common dish detergent. Rinse carefully with water afterwards. Mind that the measurement will take some time to repolarise after cleaning.

The sensor characteristics of pH sensors change with time and use. This makes it necessary to recalibrate in regular intervals.

NOTE **The instrument checks the calibration data and indicates if a sensor has to be cleaned or replaced.**

For cleaning of pH sensors please refer to the manual of the sensor.

If you have to exchange a sensor, make sure that the replacement sensor is appropriate for your application and corresponds to the equipment used. For example, check if the internal buffer of the sensor is pH 7, or, if not, that the true pH value has been entered as sensor buffer.

NOTE **If no internal buffer is given on the sensor label or in the sensor manual, this usually means that the sensor buffer is pH 7. You can verify easily by connecting it to the instrument and selecting „analog input“ in the service menu: if the reading is approx. 0mV while the sensor is immersed in pH 7, the internal buffer is also pH 7. Deviations of +/- 55mV are accepted. But a reading of 295 mV, for example, indicates that the internal buffer is pH 2.**

Mind that you have to calibrate whenever you change a sensor - or an instrument!

Regularly clean filters, flow sensors, and fittings.

Set-up

Follow the instructions of this manual. Carry out all steps described. Check both the measured values and the settings before you activate the controller.

Disposal:

For disposal please notice that the instrument contains electrolyte capacitors which have to be disposed separately.

9. Service

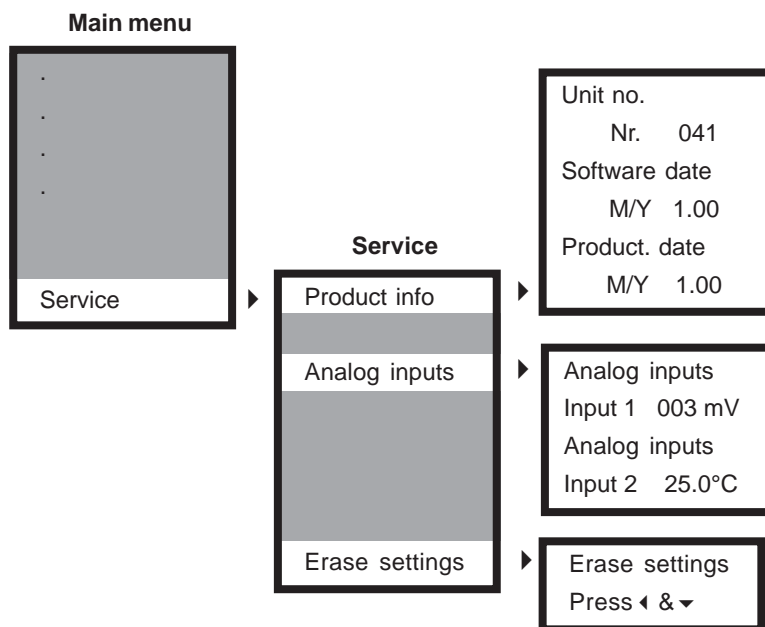

In this menu you will find information which is especially important for any inquiries, updates or problems.

9.1 Product info

These figures allow a precise identification of the instrument (hardware and software).

9.2 Analog inputs

Here you can see the raw data the instrument obtains from the sensors. They are not influenced by compensations or calibration and offer valuable information in case of problems with the measurement or the instrument.

If you have difficulties interpreting this data, send them to your supplier together with the instrument data - he will know what to do.

9.3 Erase settings (reset)

With this function you can erase all customer settings and restore the original at-works data.

The process takes some 30 seconds. When it is finished the display will show the measured value, and the controller will switch off.

10. Error messages

Error message	Cause	Measure
Slope error	Calibration did not lead to an acceptable slope. This means that the slope was either higher	Possibly there was something wrong with the calibration procedure. Check <ul style="list-style-type: none"> - the connection and the cable of the sensor - the calibration solutions - the correspondence with the calibration data - the set temperature and repeat the calibration. If the message appears again, the electrode has to be replaced.
Zero-point error	Calibration lead to a zero point higher than 55 mV or lower than -55 mV.	Here as well we advise to check first the calibration solutions and the calibration data, especially the inner buffer of the electrode. If these are okay the electrode (at least the reference electrode) has to be replaced.
Error input 1	Input 1 receives no acceptable signal.	Check the connection and the cable of the electrode.
Error input 2	Input 2 receives no acceptable signal.	Automatic temperature compensation is selected although no suitable temperature sensor is connected.
Limit 1 / 2	The measured is higher than limit 1 or lower than limit 2 for longer than the specified delay time.	Please check the dosing and the controller settings, and readjust the controller or the delay time, if necessary.
Dosage check 1 / 2	Controller 1 (or 2, resp.) gives out a 100% output for more than the defined period of time.	Please check the dosing, especially the feeding tubes and connections. Caution! Carefully check for leaking chemicals!
Ext. controller stop	The digital input has been short-circuited.	Open the digital input when you want to continue the dosage. If you have connected a level sensor, this message indicates lack of water.

Index

A

Adjustments for measurement	20
Alarm	30
Analog output	32

B

Bus adress	32
------------------	----

C

Calibration	
Calibration data	21
Procedure	21
Code	19
Connection diagram K 100 W	14
Connection diagram K100	13
Connections	9
Controller	
Acting direction	25
ON/OFF controller	24
P controller	24
PI controller	24
Controller output	32
Controller settings	
Impulse-frequency controller	26
ON/OFF controller	25
Pulse-pause controller	27

D

Digital input	28
Dimensions	10
Display contrast	33
Dosing control	31

E

Erase settings	35
Error messages	36
External controller stop	28

F

Fuse	33
------------	----

H

Hysteresis	25
------------------	----

I

Impulse-frequency controller	26
Installation K 100	11
Installation K 100 W	12
Interface	7

L	
Language	19
Limit values	30
Location	8
M	
Maintenance	33
Measuring ranges	7
Menu	
Basic settings	17
Main menu	17
Menu overview	18
O	
ORP measurement	20
P	
Parameter setting	16
Password	19
pH measurement	20
Product info	35
Protection class	8
Pt100	22
R	
RC filter	9
Registration output	32
Relays	7
Contact rating	8
Manual operation	29
Status of the relays	15
S	
Sensor buffer	21
Sensor zero-point	21
Serial interface	7
Service	35
Set points	24
Slope	21
Software version	5
Start delay	
Alarm	30
Controller	28
T	
Technical data	8
Temperature compensation	22
Temperature sensor	22
Z	
Zero-point	21

Customer settings - for reference!

Instrument:

Identification / location:

Type: Date of installation

Instrument no..... Software version

Measurement:

pH ORP

Cal. solution 1..... pH

Cal. solution 2..... pH

Sensor buffer..... pH

Temperature compensation:

Manual Automatic

Temperature: °C

Correction °C

Current output:

0-20mA 4-20mA for: Meas. value controller S1 controller S2

Begin:

End:

Controller:

Controller S1

Direction: raise lower

Set point:

Hysteresys

P range

Integral timesek.

Pulse pause time..... sek.

Min. pulse sek.

Pulse frequency*100 / h

Dosage check min

Controller S2

Direction: raise lower

Set point:

Hysteresys

P range

Integral timesek.

Pulse pause time sek.

Min. pulse sek.

Pulse frequency*100 / h

Dosage check min

Start delay:

Delay time min.

Alarm:

Limit S1

Limit S2

Dealy time min.

Digital input:

Normally closed Normally open

Interface RS 485:

Bus adress
